

GSP80-220-15

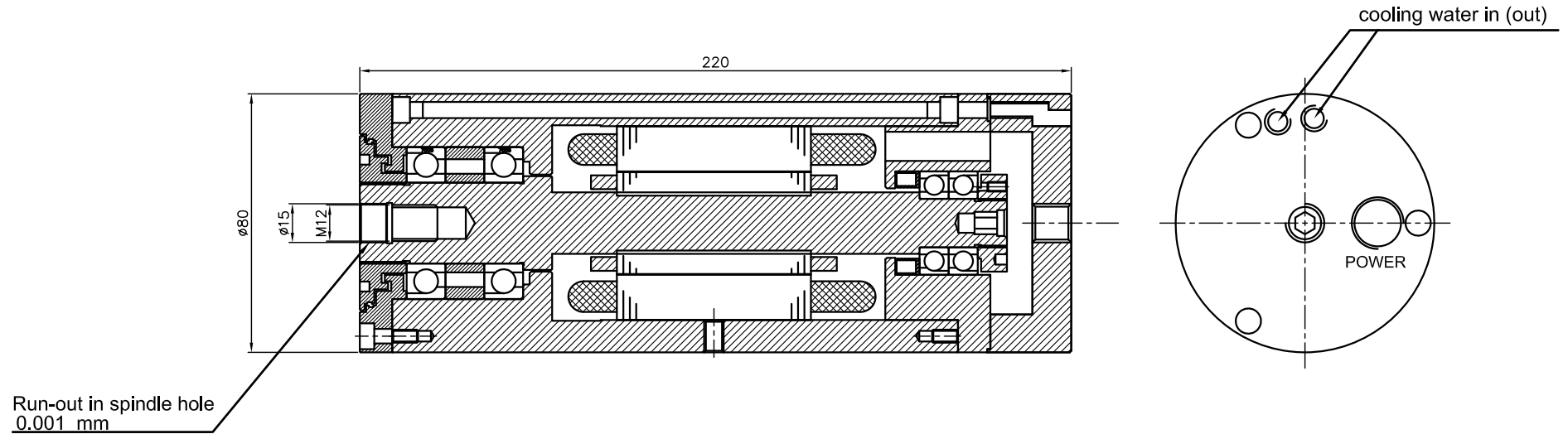

Specification	Units
Maximun Speed (最高轉速)	20000 R.P.M
Maximun Dynamic Runout (偏擺精度)	spindle hole 0.001 mm
Cooling Water Flow Rate (冷卻水流量)	56.9 IMP(L/Hour)
Cooling Water Inlet Temperature (冷卻水進入溫度)	18~22 °C
Axial Failure Load (Push) (軸向承受壓力)	25 kgf
Body Size (外部尺寸)	80 mm (h6)
Weight (重量)	7 kg

MOTOR POWER: 1.5 KW
MOTOR POLES : 2
MOTOR RATED VOLTAGE : 200 V
MOTOR RATED SPEED: 11800rpm
MOTOR RATED CURRET: 3A
MOTOR RATED FREQUENCY: 200HZ